

TYPICAL FRAME ELEVATIONS

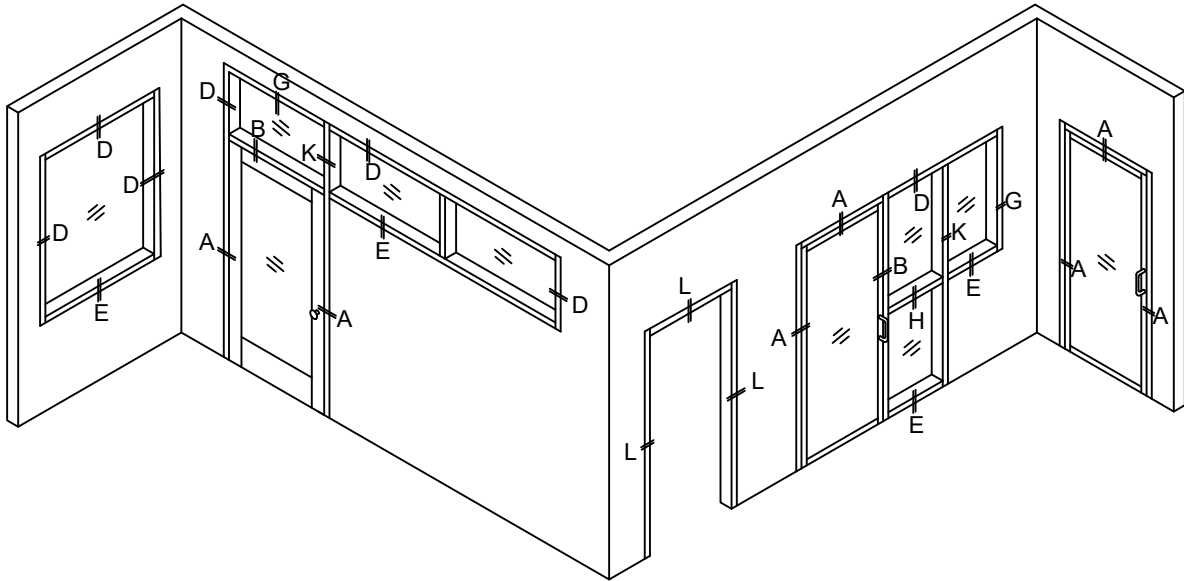

PARTIAL HEIGHT FRAME ELEVATIONS

525 WALL SERIES FOR 5¹/₄" PARTITION

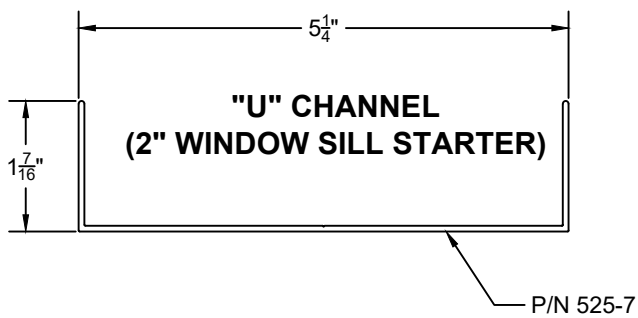
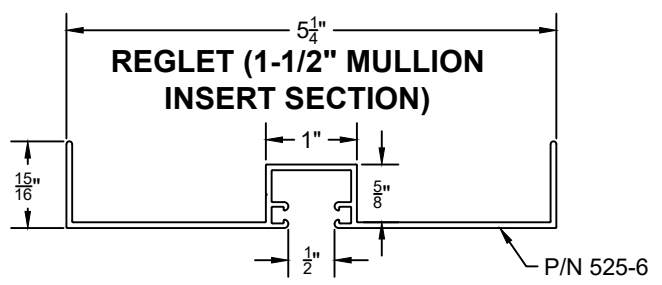
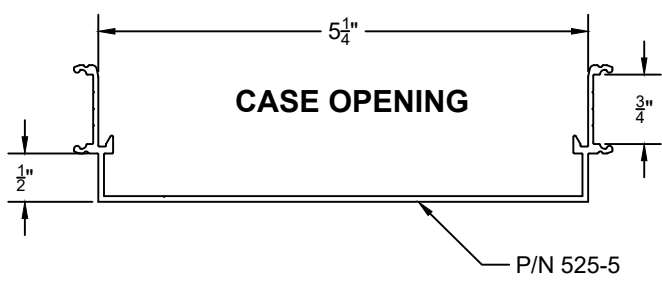
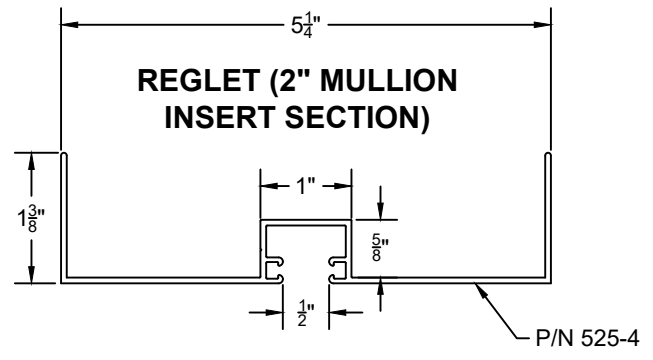
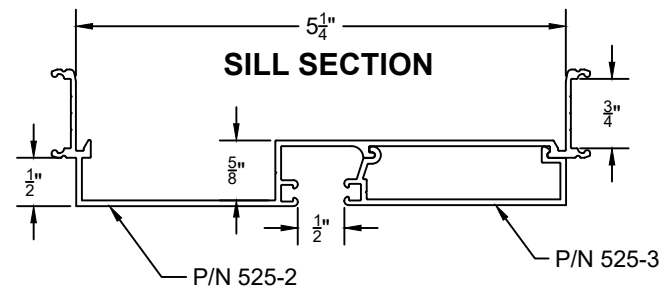
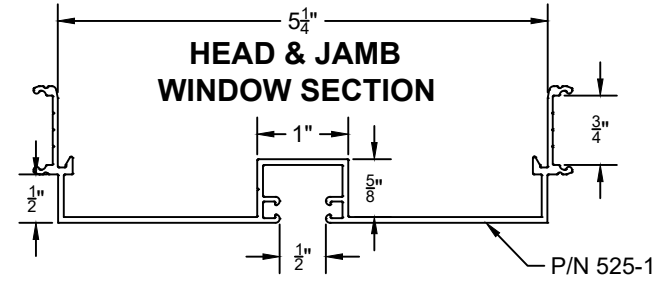
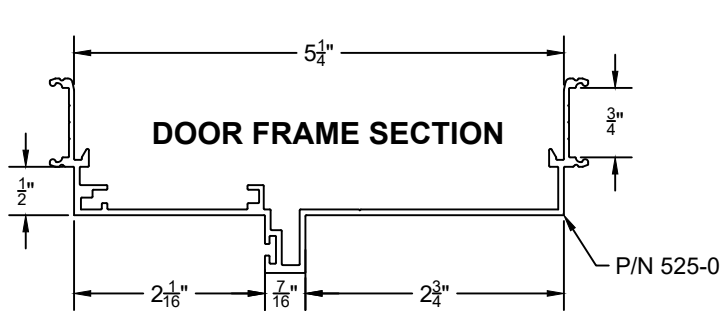

WALL SYSTEM

525 WALL SERIES WITH 2" TRIM FOR 5¹/₄" PARTITION

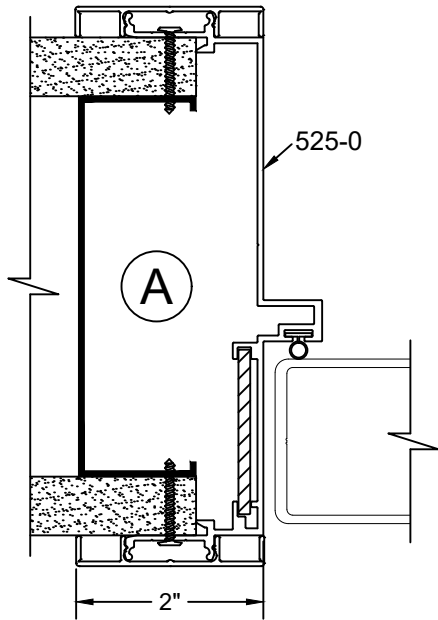

DOOR JAMB

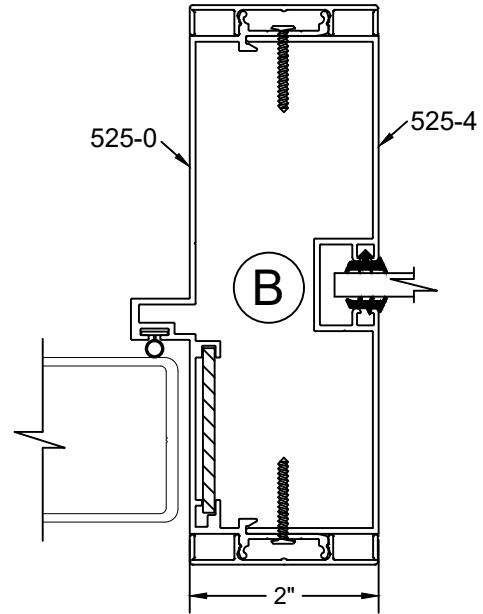

DOOR JAMB WITH SIDELITE
2" MULLION

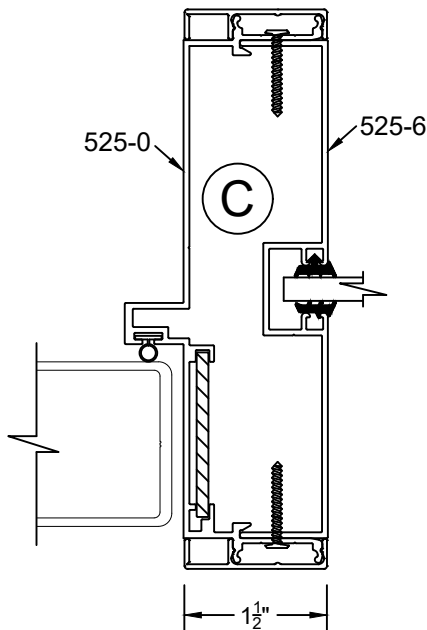

DOOR JAMB WITH SIDELITE
1 1/2" MULLION

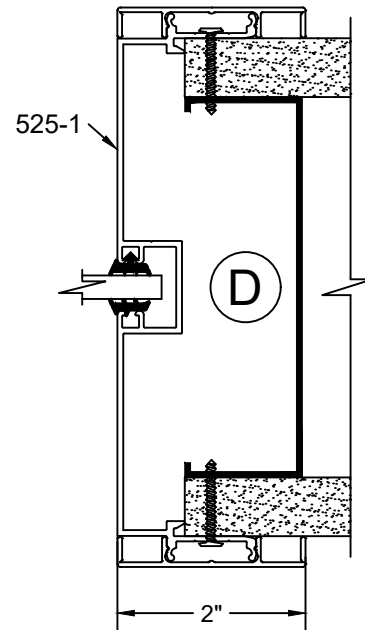

GLASS JAMB

525 WALL SERIES WITH 2" TRIM FOR 5 $\frac{1}{4}$ " PARTITION

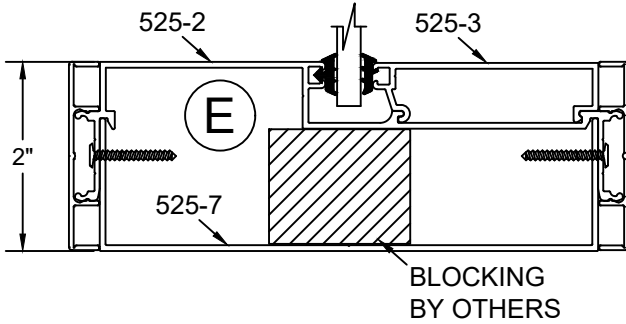

2" SILL

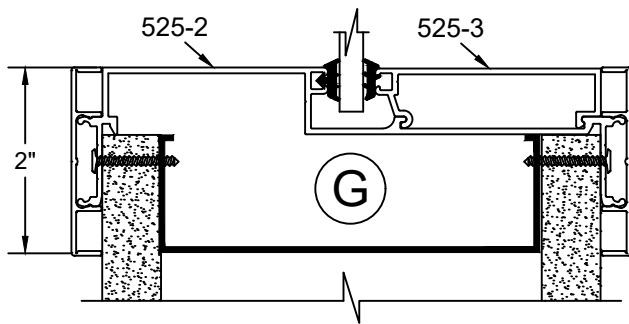

SILL AT WALL

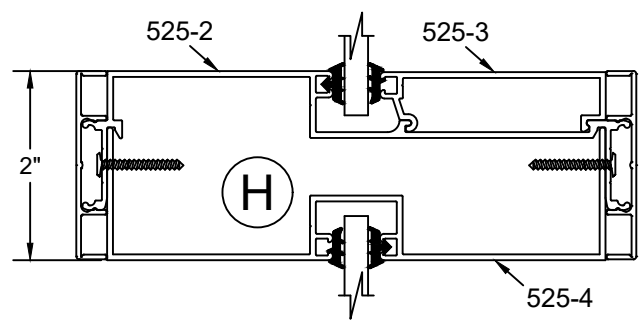

2" HORIZONTAL MULLION

525 WALL SERIES WITH 2" TRIM FOR 5¹/₄" PARTITION

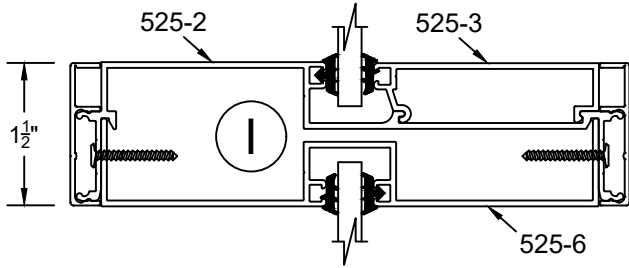

1 1/2" HORIZONTAL MULLION

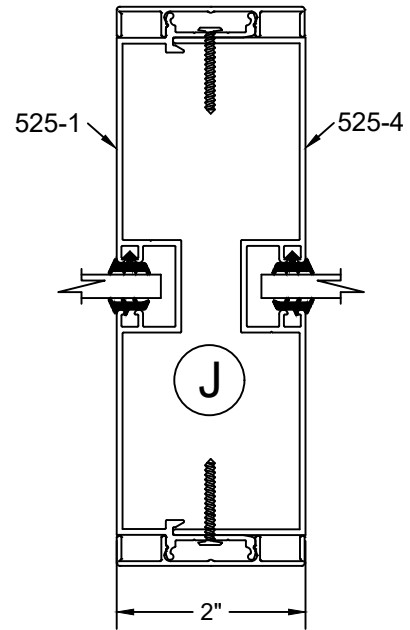

2" VERTICAL MULLION

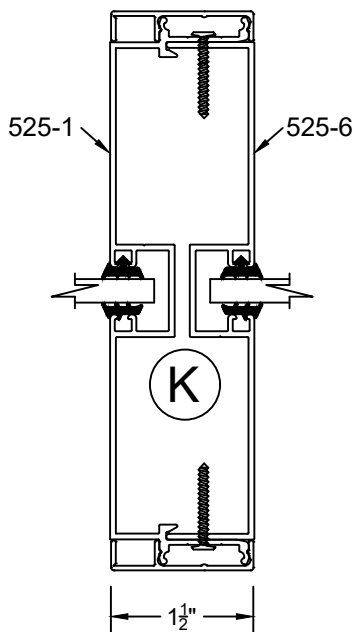

1 1/2" VERTICAL MULLION

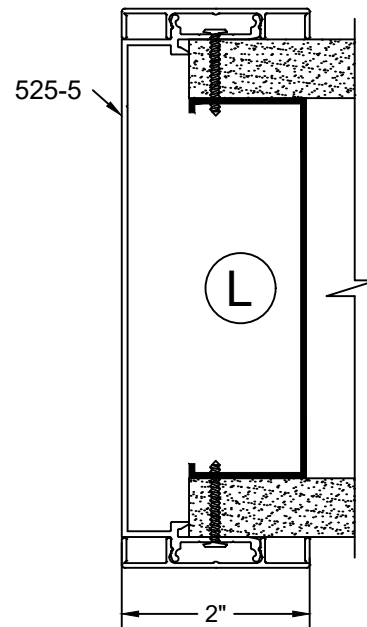

CASED OPENING JAMB

525 WALL SERIES WITH 2" TRIM FOR 5 $\frac{1}{4}$ " PARTITION

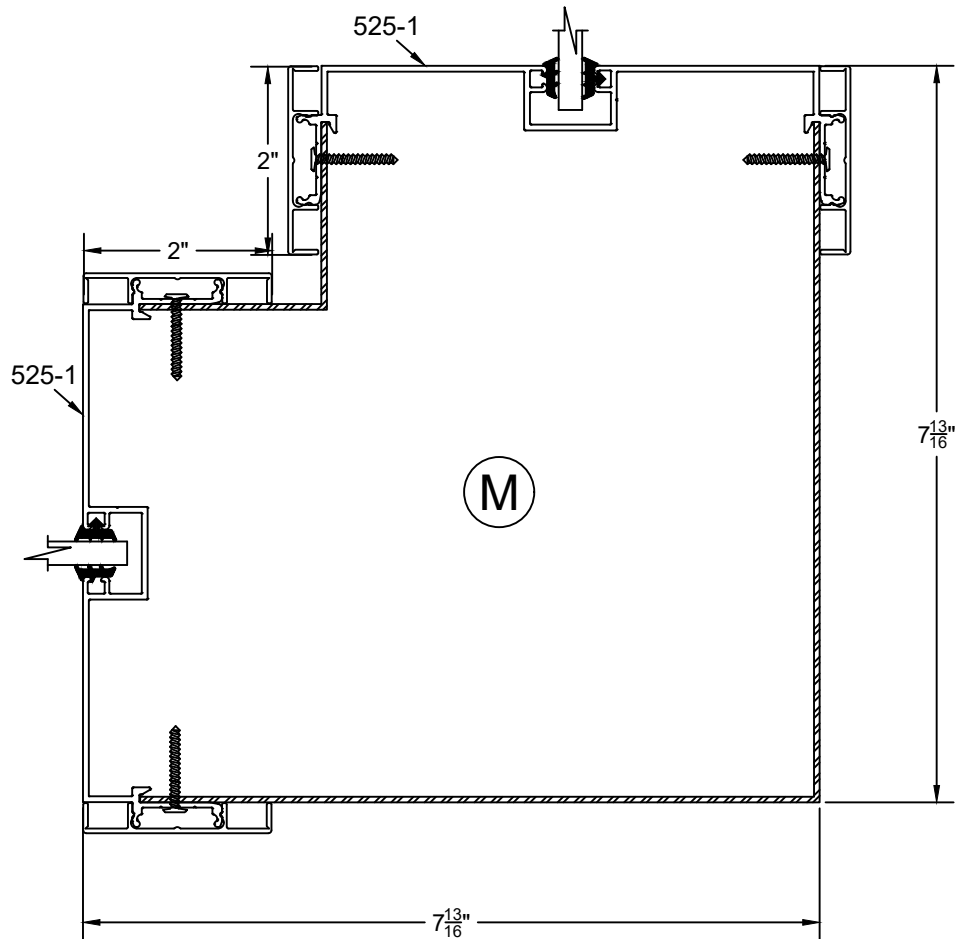

90° CORNER POST

525 WALL SERIES WITH 2" TRIM FOR 5 $\frac{1}{4}$ " PARTITION

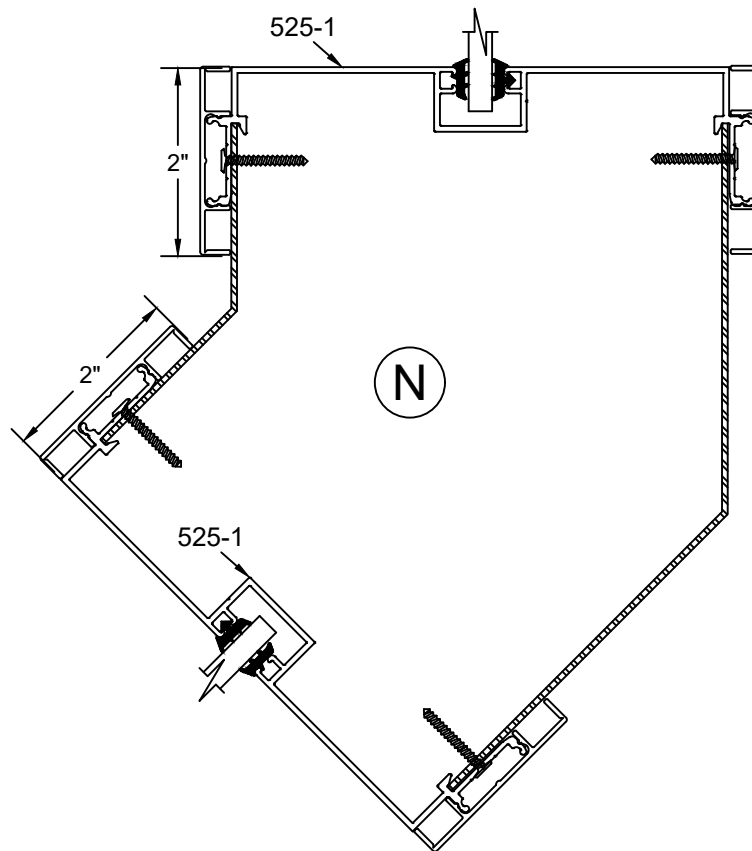

CUSTOM CORNER POST

525 WALL SERIES WITH 2" TRIM FOR 5 $\frac{1}{4}$ " PARTITION

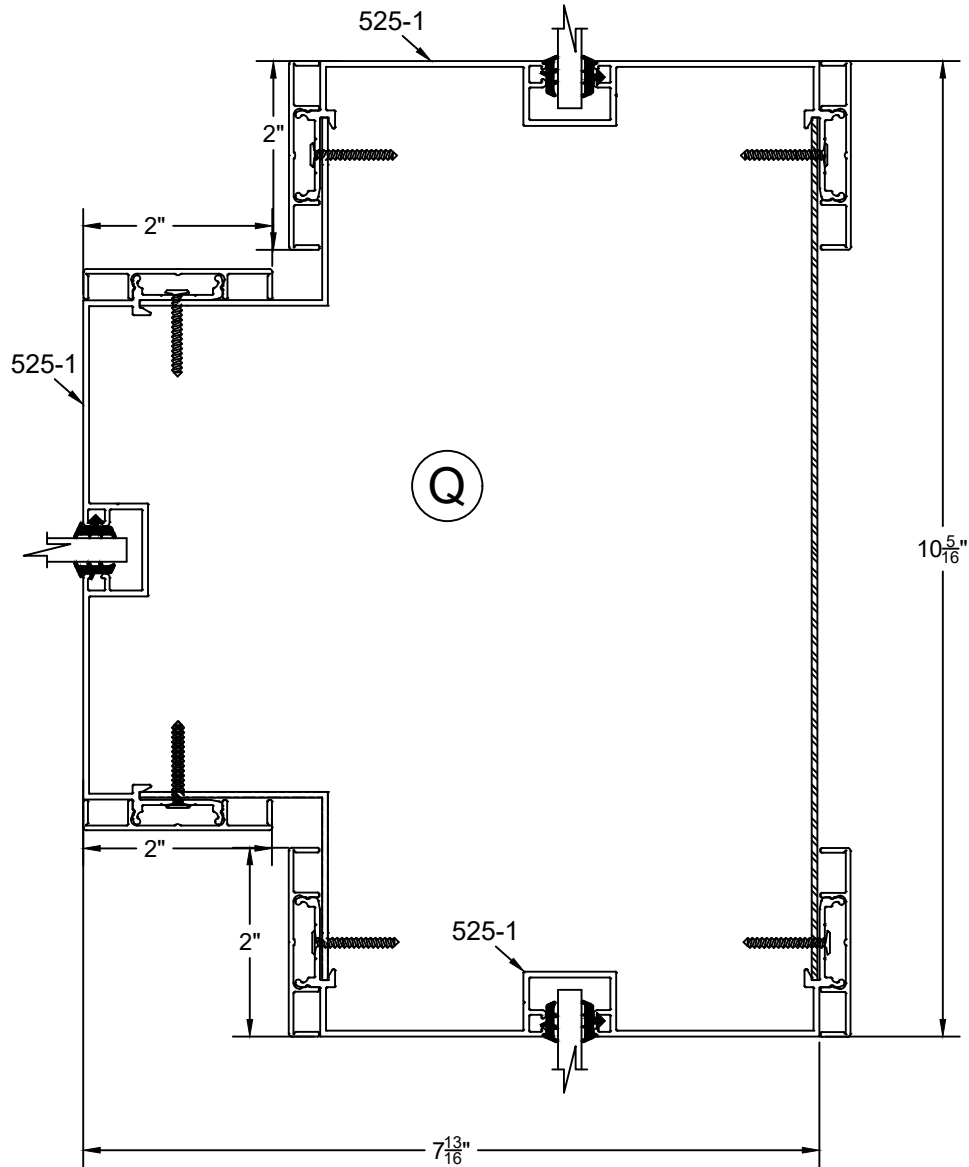

T - POST