

CONFIDENTIALITY NOTICE: THIS DRAWING, INCLUDING ANY ATTACHMENTS, IS FOR THE SOLE USE OF THE INTENDED RECIPIENT(S) AND MAY CONTAIN CONFIDENTIAL AND PRIVILEGED INFORMATION. ANY UNAUTHORIZED REVIEW, USE, DISCLOSURE OR DISTRIBUTION IS PROHIBITED. IF YOU ARE NOT THE INTENDED RECIPIENT, PLEASE CONTACT SPECIAL-LITE, INC. AND DESTROY ALL COPIES OF THE ORIGINAL DRAWING.

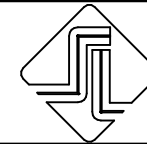

Special-Lite
ENGINEERED ARCHITECTURAL SOLUTIONS

860 SOUTH WILLIAMS STREET
DECATUR, MICHIGAN 49045
Ph: (800) 821-6531
Fx: (800) 423-7610
www.special-lite.com

UNLESS OTHERWISE SPECIFIED
0.0" ± 0.060"
0.00" ± 0.030"
0.000" ± 0.010"
0.0000" ± 0.002"

∠ ± 2.0°
CORNER RADI 0.015"
ALL MACHINED SURFACES
TO BE FREE OF BURS

DRAWN
Jason Couse

6/29/2018

CHECKED

APPROVED

MFG

MATERIAL

TITLE

2" Mitered Trim Clip Diagram

SIZE

FILE NAME

B

487 Clip Drawing (2 inch trim Mitered).dwg

REV

SCALE

PART #

SHEET 1 OF 8

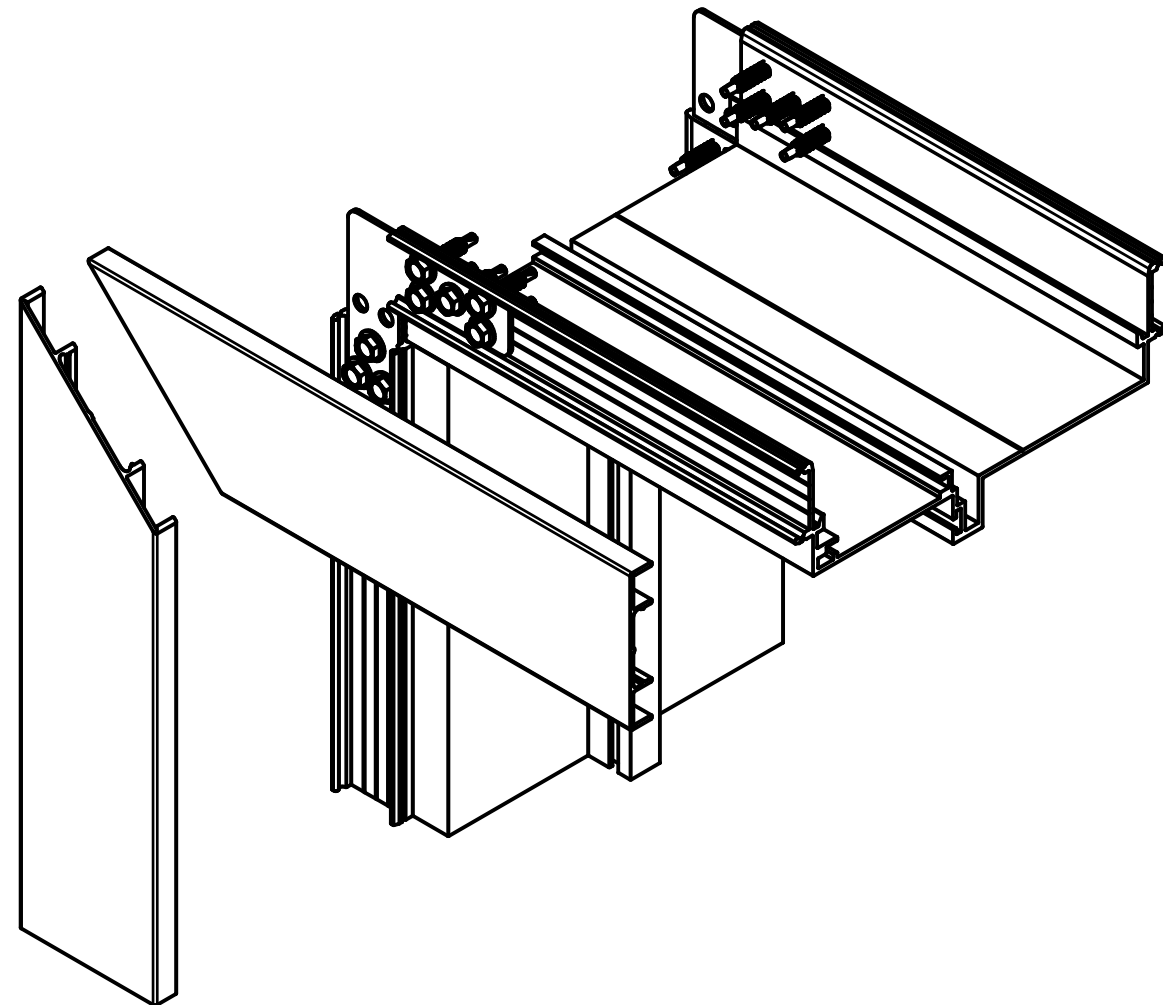

Clip Diagram - A

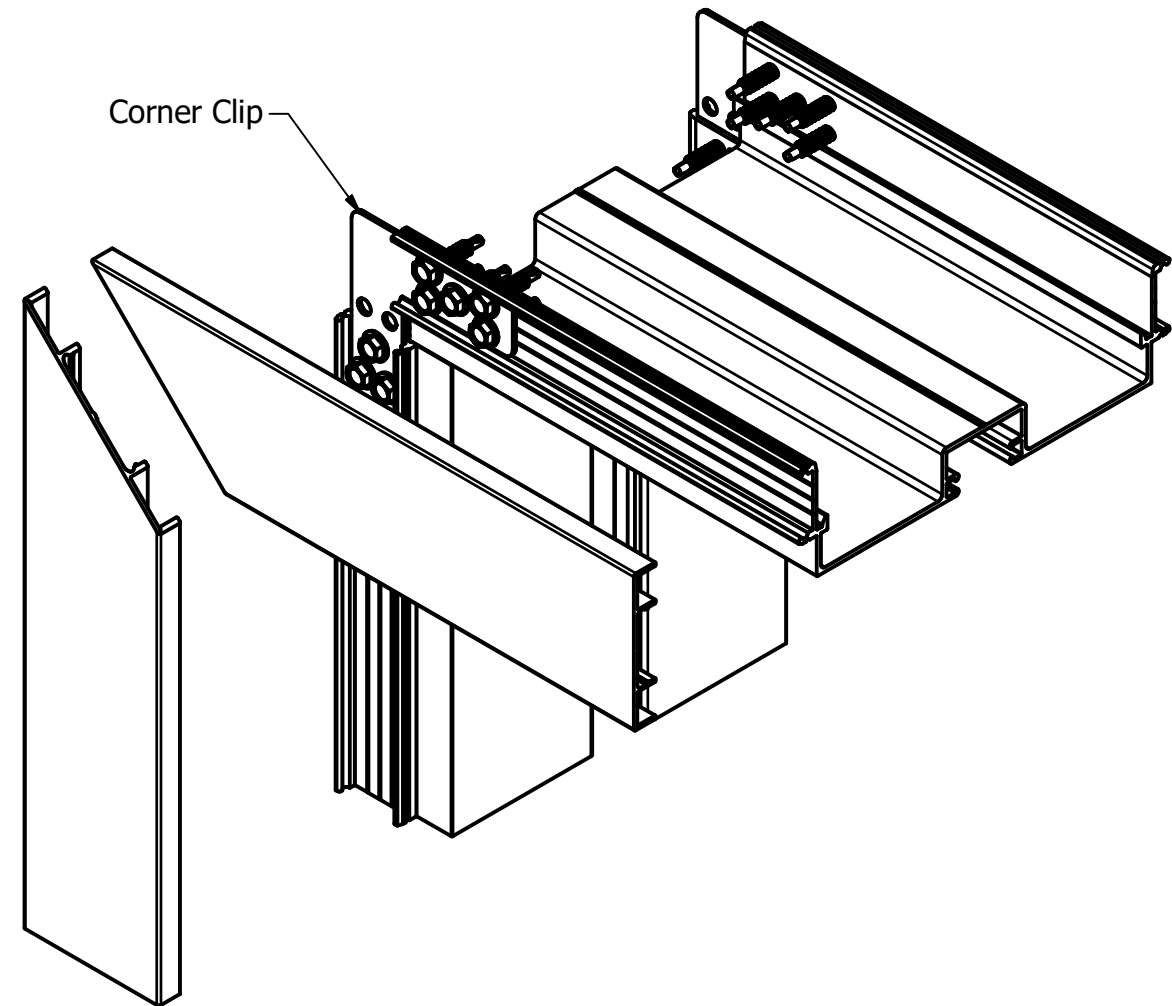

Clip Diagram - B

CONFIDENTIALITY NOTICE: THIS DRAWING, INCLUDING ANY ATTACHMENTS, IS FOR THE SOLE USE OF THE INTENDED RECIPIENT(S) AND MAY CONTAIN CONFIDENTIAL AND PRIVILEGED INFORMATION. ANY UNAUTHORIZED REVIEW, USE, DISCLOSURE OR DISTRIBUTION IS PROHIBITED. IF YOU ARE NOT THE INTENDED RECIPIENT, PLEASE CONTACT SPECIAL-LITE, INC. AND DESTROY ALL COPIES OF THE ORIGINAL DRAWING.



Special-Lite
ENGINEERED ARCHITECTURAL SOLUTIONS

860 SOUTH WILLIAMS STREET
DECATUR, MICHIGAN 49045
Ph: (800) 821-6531
Fx: (800) 423-7610
www.special-lite.com

UNLESS OTHERWISE SPECIFIED
0.0" ± 0.060"
0.00" ± 0.030"
0.000" ± 0.010"
0.0000" ± 0.002"
∠ ± 2.0°
CORNER RADI 0.015"
ALL MACHINED SURFACES
TO BE FREE OF BURS

DRAWN Jason Couse	6/29/2018
CHECKED	
APPROVED	
MFG	
MATERIAL	

TITLE 2" Mitered Trim Clip Diagram		REV
SIZE B	FILE NAME 487 Clip Drawing (2 inch trim Mitered).dwg	
SCALE 1 / 2	PART #	SHEET 2 OF 8

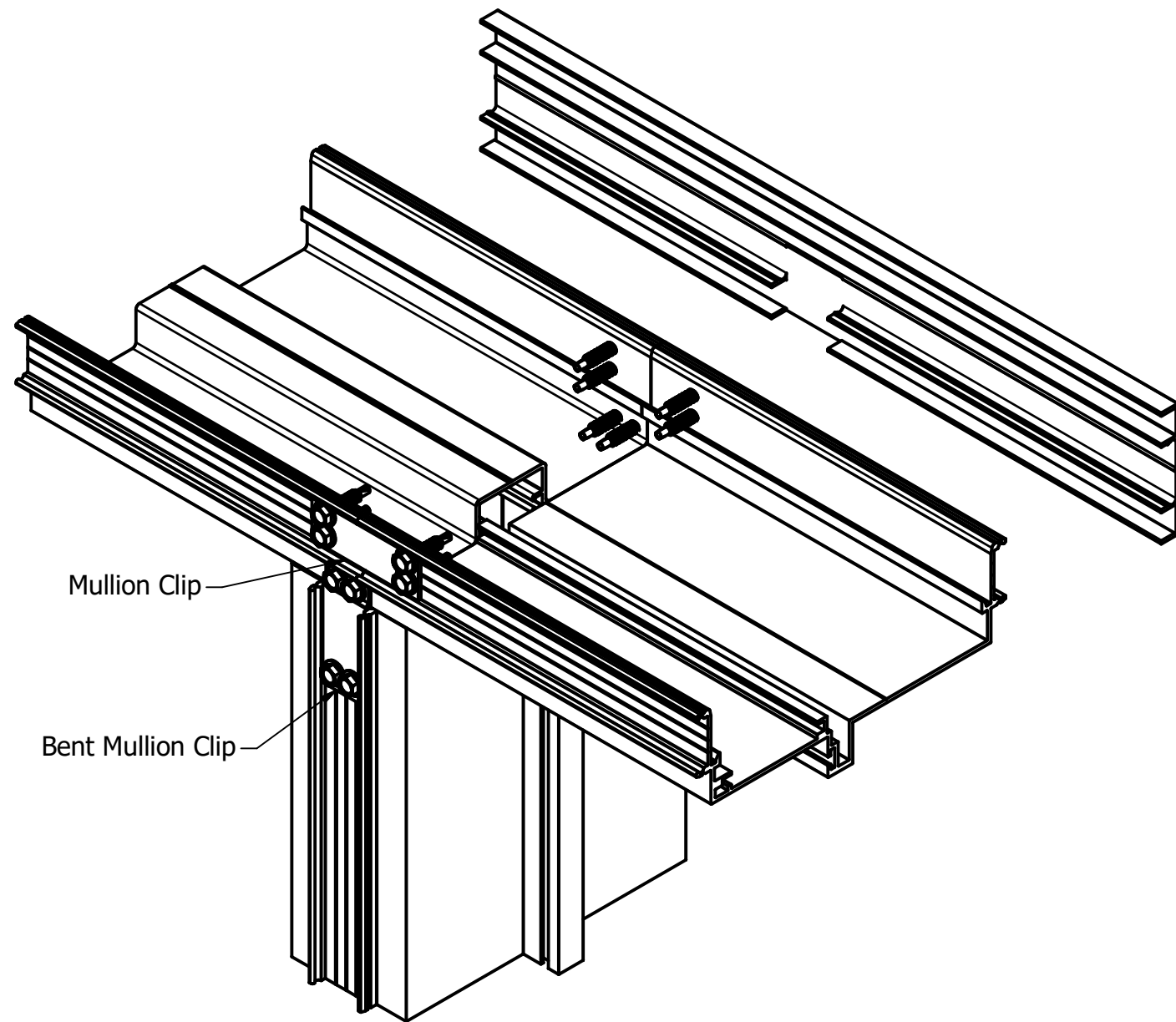

Clip Diagram - C

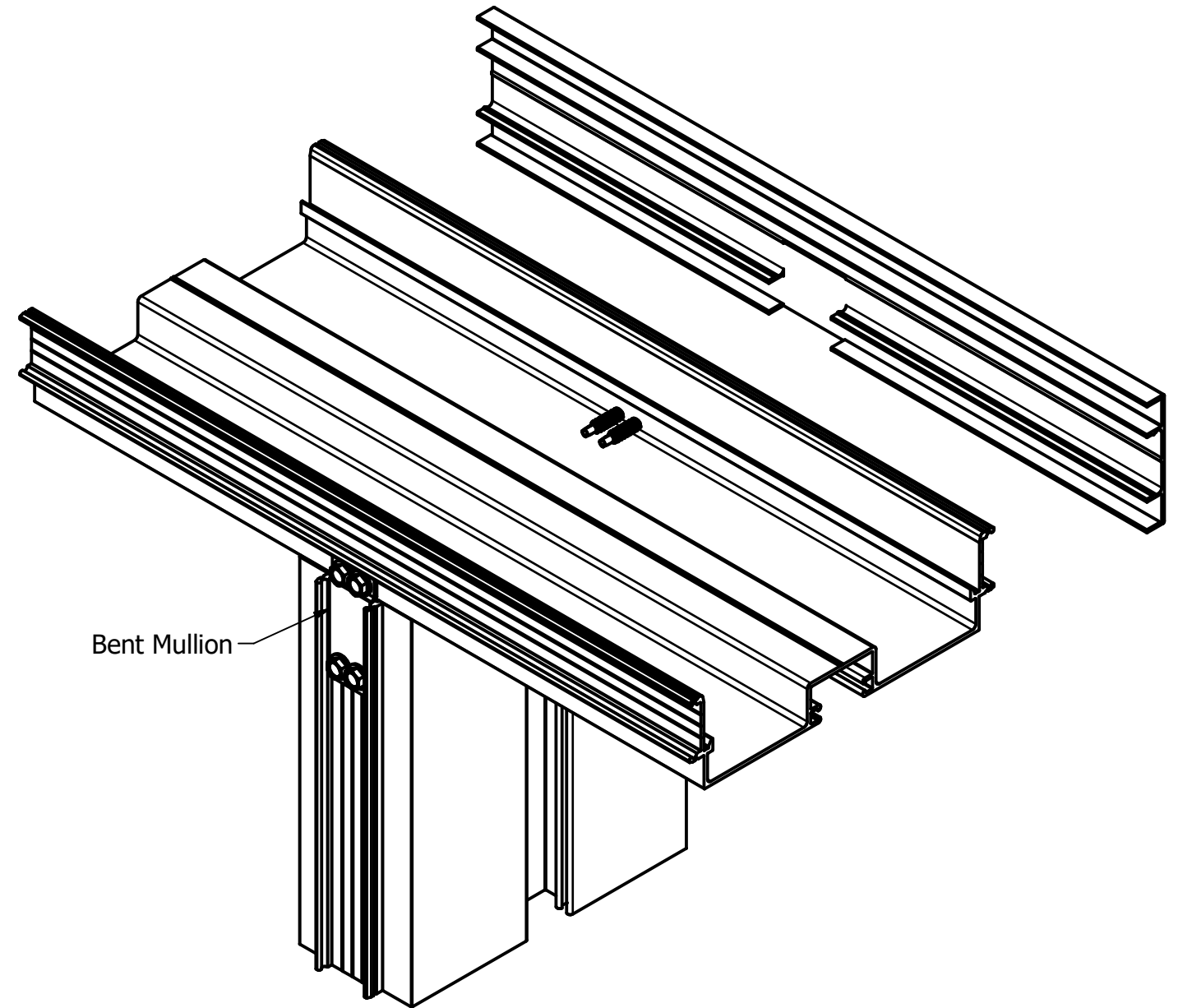

Clip Diagram - D

CONFIDENTIALITY NOTICE: THIS DRAWING, INCLUDING ANY ATTACHMENTS, IS FOR THE SOLE USE OF THE INTENDED RECIPIENT(S) AND MAY CONTAIN CONFIDENTIAL AND PRIVILEGED INFORMATION. ANY UNAUTHORIZED REVIEW, USE, DISCLOSURE OR DISTRIBUTION IS PROHIBITED. IF YOU ARE NOT THE INTENDED RECIPIENT, PLEASE CONTACT SPECIAL-LITE, INC. AND DESTROY ALL COPIES OF THE ORIGINAL DRAWING.

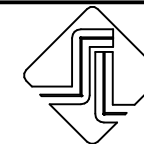

Special-Lite
ENGINEERED ARCHITECTURAL SOLUTIONS

860 SOUTH WILLIAMS STREET
DECATUR, MICHIGAN 49045
Ph: (800) 821-6531
Fx: (800) 423-7610
www.special-lite.com

UNLESS OTHERWISE SPECIFIED
0.0" ± 0.060"
0.00" ± 0.030"
0.000" ± 0.010"
0.0000" ± 0.002"
∠ ± 2.0°
CORNER RADI 0.015"
ALL MACHINED SURFACES
TO BE FREE OF BURRS

DRAWN
Jason Couse

6/29/2018

CHECKED

APPROVED

MFG

MATERIAL

TITLE

2" Mitered Trim Clip Diagram

SIZE

B

FILE NAME

487 Clip Drawing (2 inch trim Mitered).dwg

REV

SCALE

1 / 2

PART #

SHEET 3 OF 8

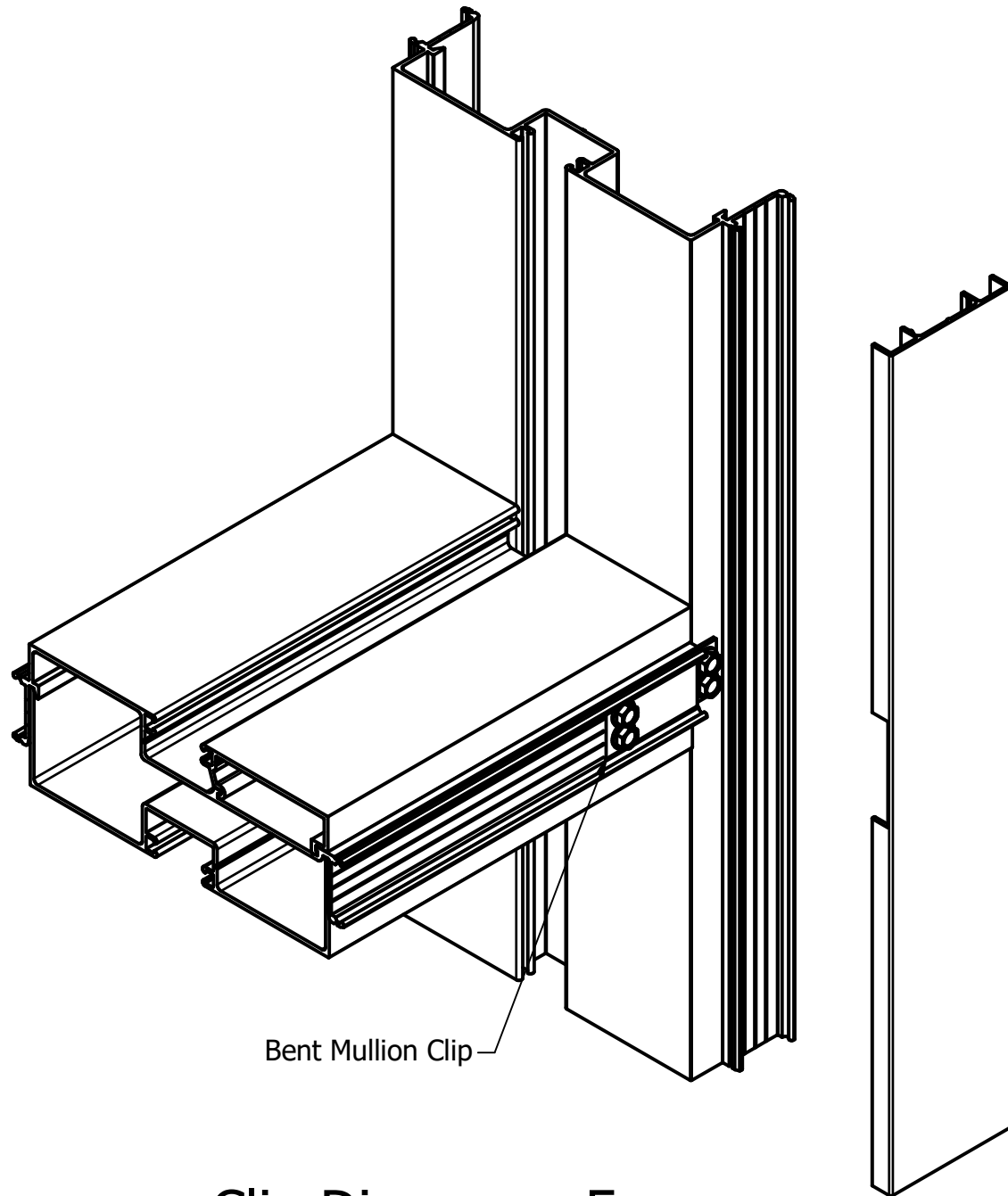

Bent Mullion Clip

Clip Diagram - F

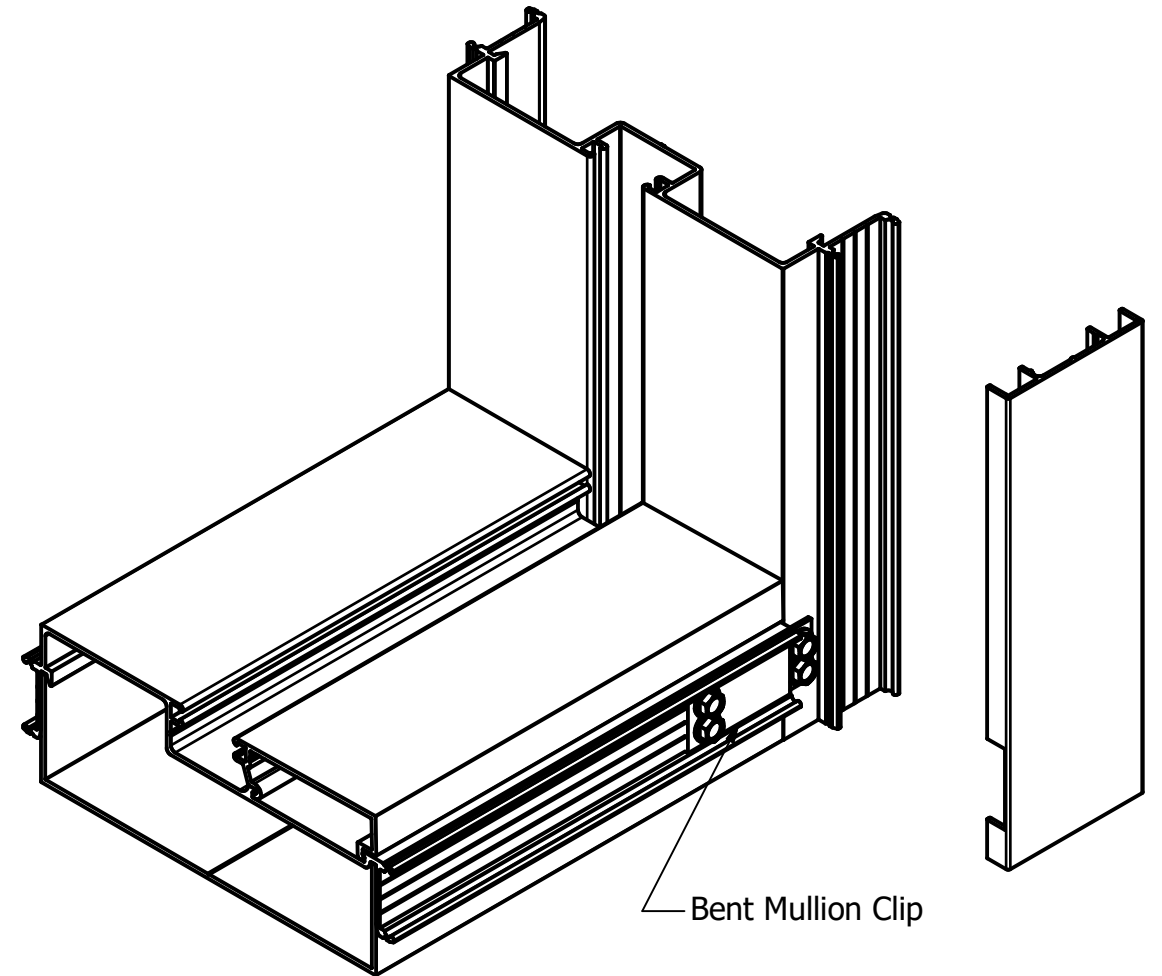

Bent Mullion Clip

Clip Diagram - G

CONFIDENTIALITY NOTICE: THIS DRAWING, INCLUDING ANY ATTACHMENTS, IS FOR THE SOLE USE OF THE INTENDED RECIPIENT(S) AND MAY CONTAIN CONFIDENTIAL AND PRIVILEGED INFORMATION. ANY UNAUTHORIZED REVIEW, USE, DISCLOSURE OR DISTRIBUTION IS PROHIBITED. IF YOU ARE NOT THE INTENDED RECIPIENT, PLEASE CONTACT SPECIAL-LITE, INC. AND DESTROY ALL COPIES OF THE ORIGINAL DRAWING.



Special-Lite[®]

ENGINEERED ARCHITECTURAL SOLUTIONS

860 SOUTH WILLIAMS STREET
 DECATUR, MICHIGAN 49045
 Ph: (800) 821-6531
 Fx: (800) 423-7610
 www.special-lite.com

UNLESS OTHERWISE SPECIFIED
 0.0" ± 0.060"
 0.00" ± 0.030"
 0.000" ± 0.010"
 0.0000" ± 0.002"

∠ ± 2.0°
 CORNER RADI 0.015"
 ALL MACHINED SURFACES
 TO BE FREE OF BURRS

DRAWN
 Jason Couse

CHECKED

APPROVED

MFG

MATERIAL

6/29/2018

TITLE

2" Mitered Trim Clip Diagram

SIZE

B

FILE NAME

487 Clip Drawing (2 inch trim Mitered).dwg

REV

SCALE

1 / 2

PART #

SHEET 4 OF 8

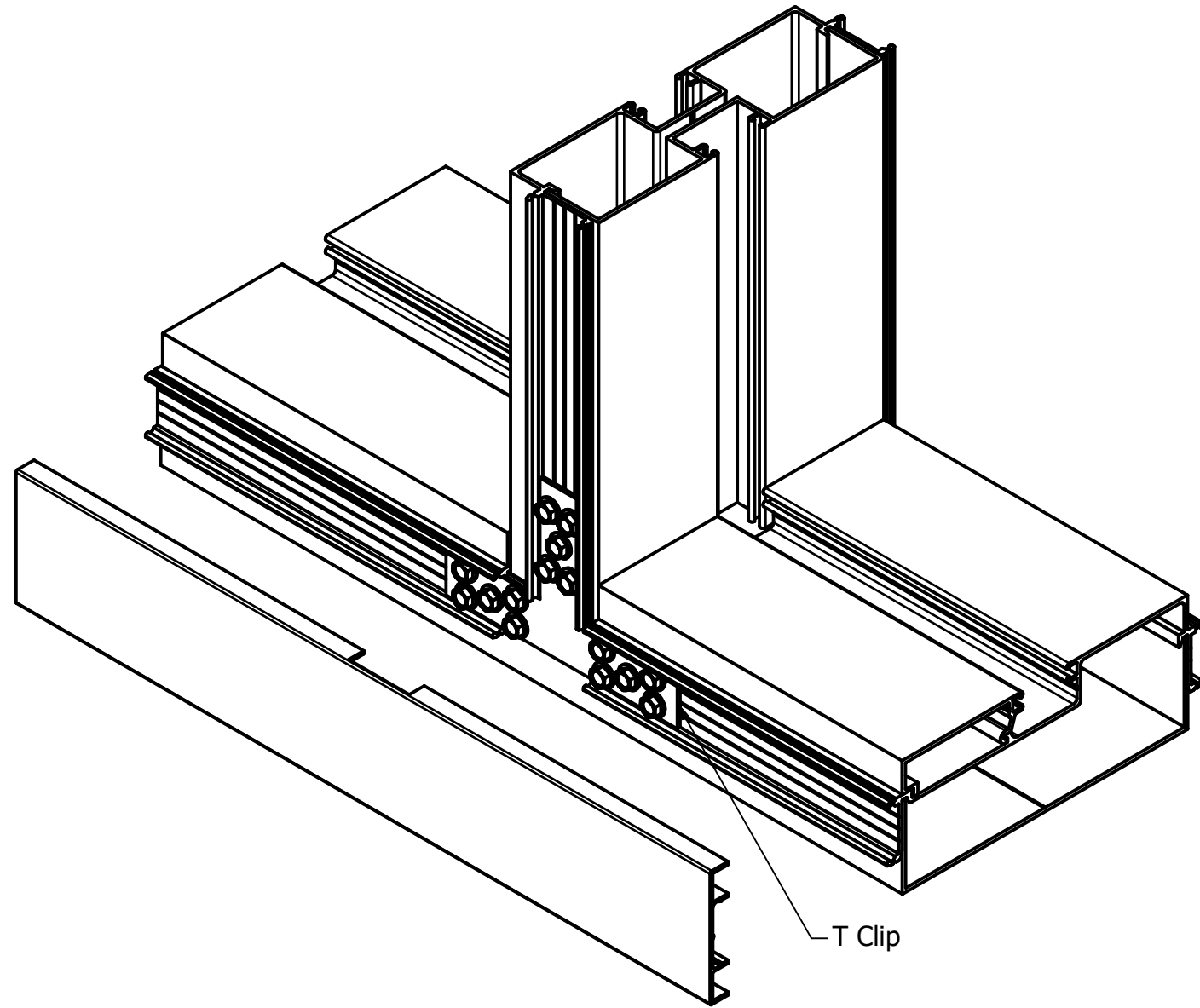

T Clip

Clip Diagram - H

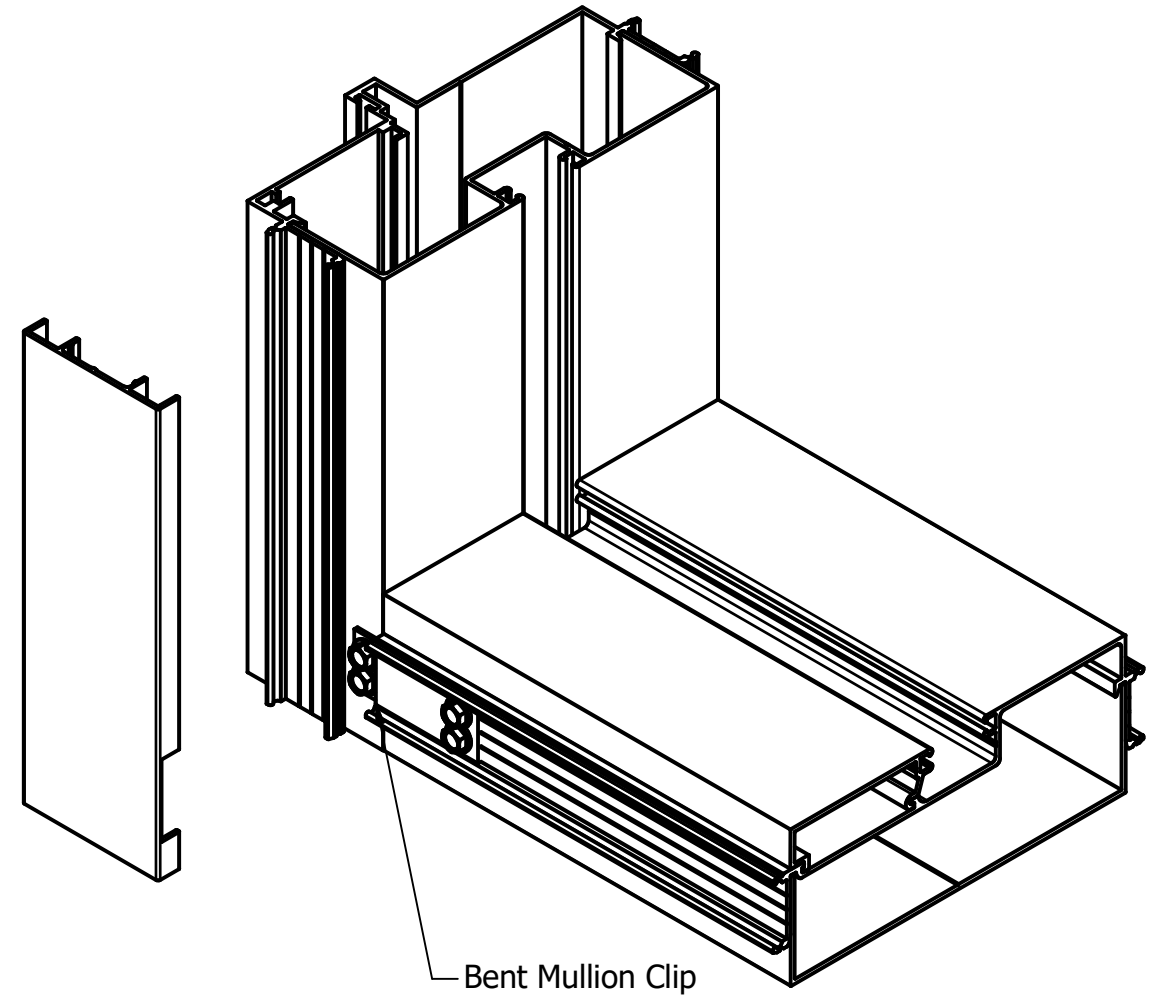

Bent Mullion Clip

Clip Diagram - I

CONFIDENTIALITY NOTICE: THIS DRAWING, INCLUDING ANY ATTACHMENTS, IS FOR THE SOLE USE OF THE INTENDED RECIPIENT(S) AND MAY CONTAIN CONFIDENTIAL AND PRIVILEGED INFORMATION. ANY UNAUTHORIZED REVIEW, USE, DISCLOSURE OR DISTRIBUTION IS PROHIBITED. IF YOU ARE NOT THE INTENDED RECIPIENT, PLEASE CONTACT SPECIAL-LITE, INC. AND DESTROY ALL COPIES OF THE ORIGINAL DRAWING.

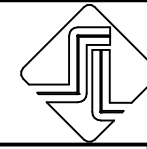

Special-Lite
ENGINEERED ARCHITECTURAL SOLUTIONS

860 SOUTH WILLIAMS STREET
DECATUR, MICHIGAN 49045
Ph: (800) 821-6531
Fx: (800) 423-7610
www.special-lite.com

UNLESS OTHERWISE SPECIFIED
0.0" ± 0.060"
0.00" ± 0.030"
0.000" ± 0.010"
0.0000" ± 0.002"

∠ ± 2.0°
CORNER RADI 0.015"
ALL MACHINED SURFACES
TO BE FREE OF BURS

DRAWN
Jason Couse

CHECKED

APPROVED

MFG

MATERIAL

6/29/2018

TITLE

2" Mitered Trim Clip Diagram

SIZE

B

FILE NAME

487 Clip Drawing (2 inch trim Mitered).dwg

REV

SCALE

1 / 2

PART #

SHEET 5 OF 8

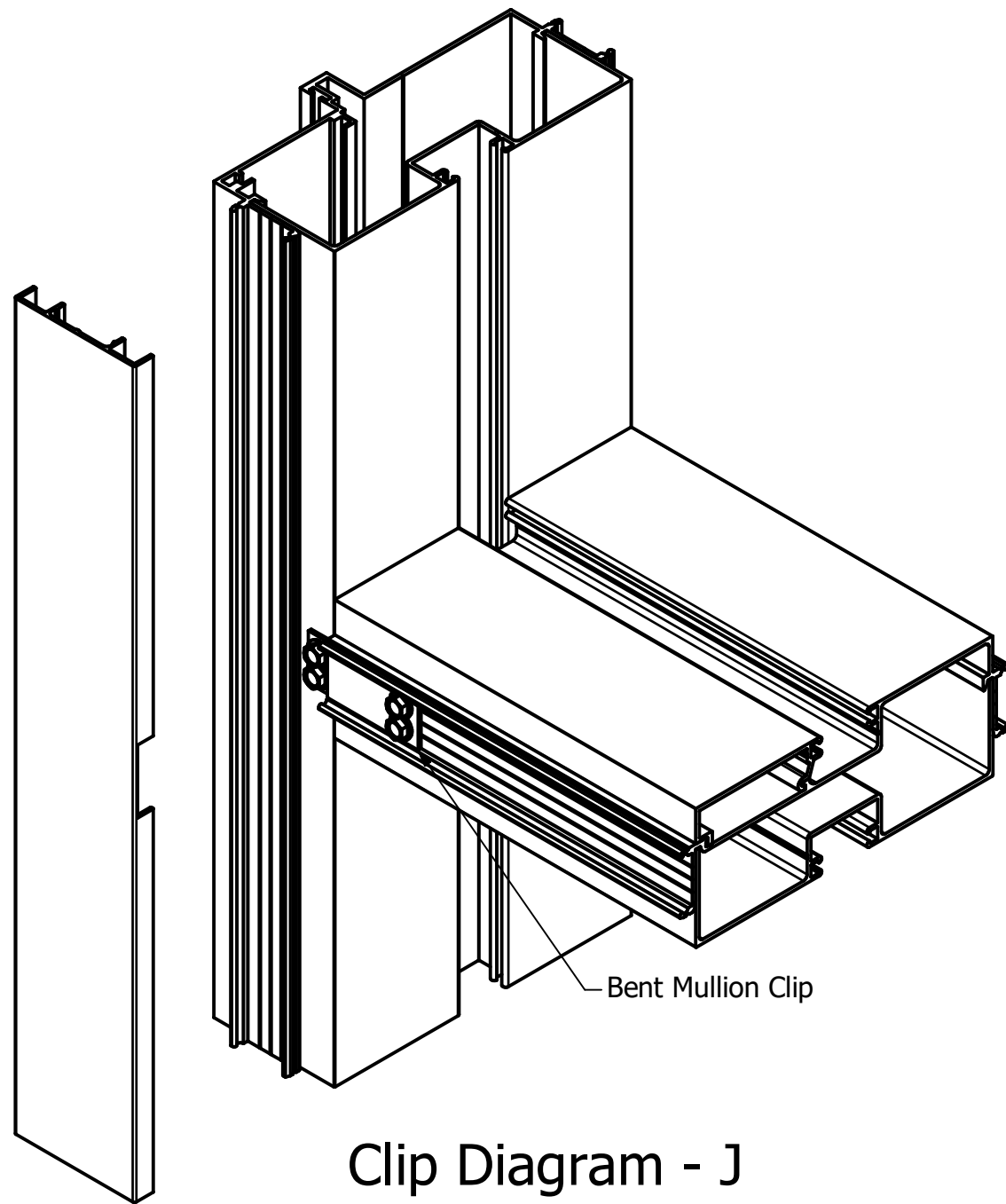

Clip Diagram - J

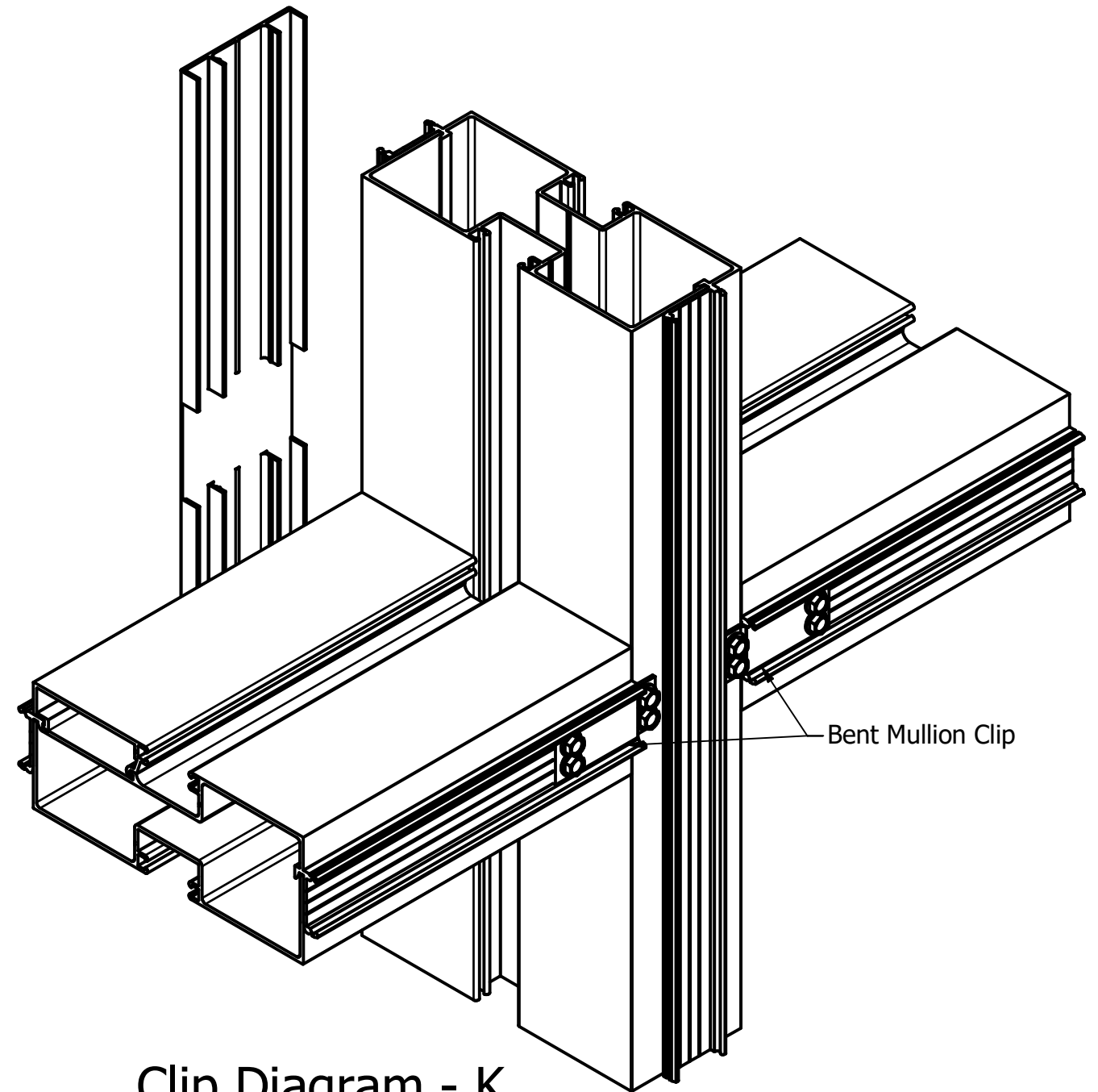

Clip Diagram - K

CONFIDENTIALITY NOTICE: THIS DRAWING, INCLUDING ANY ATTACHMENTS, IS FOR THE SOLE USE OF THE INTENDED RECIPIENT(S) AND MAY CONTAIN CONFIDENTIAL AND PRIVILEGED INFORMATION. ANY UNAUTHORIZED REVIEW, USE, DISCLOSURE OR DISTRIBUTION IS PROHIBITED. IF YOU ARE NOT THE INTENDED RECIPIENT, PLEASE CONTACT SPECIAL-LITE, INC. AND DESTROY ALL COPIES OF THE ORIGINAL DRAWING.

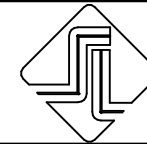

Special-Lite[®]

ENGINEERED ARCHITECTURAL SOLUTIONS

860 SOUTH WILLIAMS STREET
 DECATUR, MICHIGAN 49045
 Ph: (800) 821-6531
 Fx: (800) 423-7610
 www.special-lite.com

UNLESS OTHERWISE SPECIFIED
 0.0" ± 0.060"
 0.00" ± 0.030"
 0.000" ± 0.010"
 0.0000" ± 0.002"

∠ ± 2.0°
 CORNER RADI 0.015"
 ALL MACHINED SURFACES
 TO BE FREE OF BURS

DRAWN
 Jason Couse

CHECKED

APPROVED

MFG

MATERIAL

6/29/2018

TITLE

2" Mitered Trim Clip Diagram

SIZE

B

FILE NAME

487 Clip Drawing (2 inch trim Mitered).dwg

REV

SCALE

1 / 2

PART #

SHEET 6 OF 8

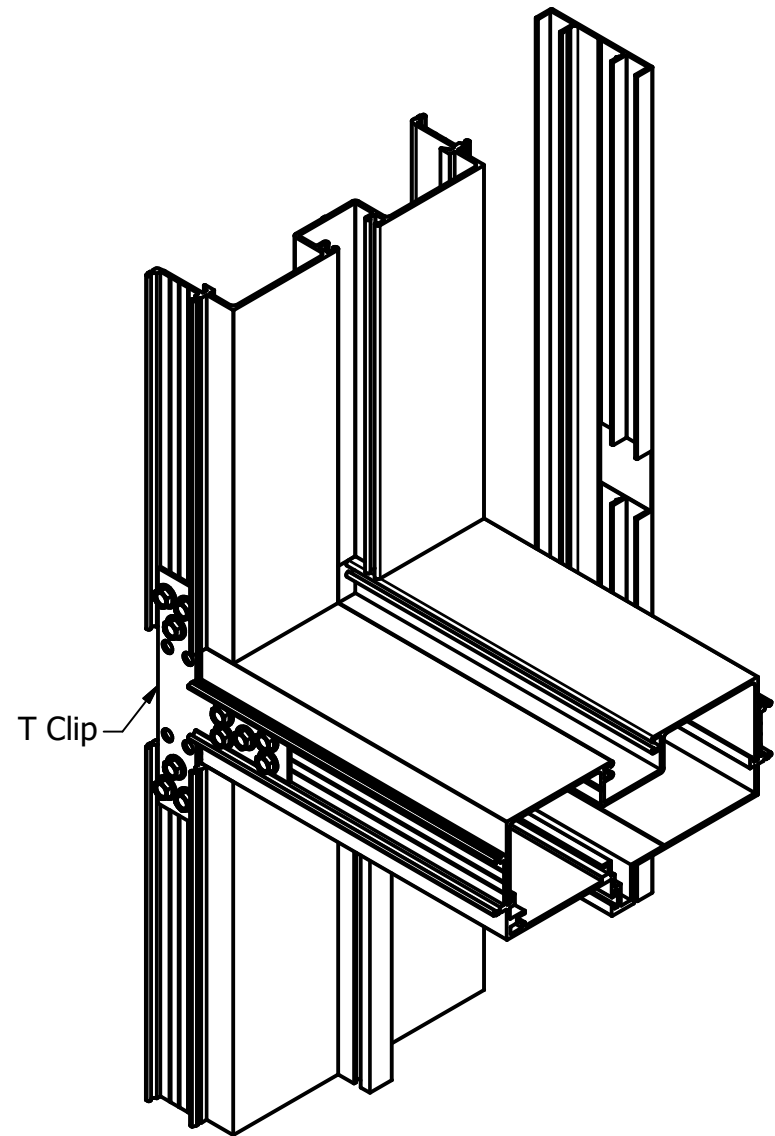

Clip Diagram - L

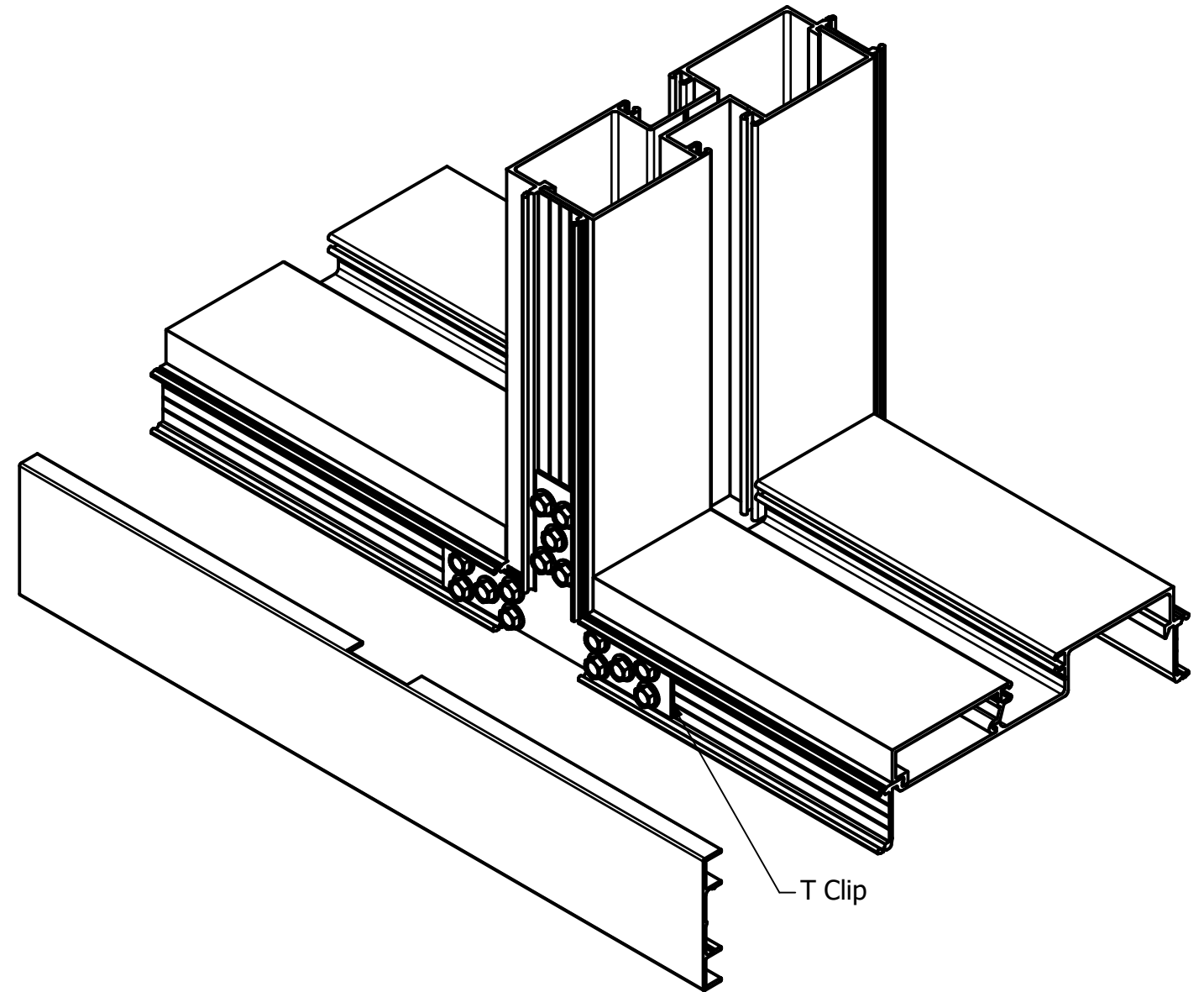

Clip Diagram - M

CONFIDENTIALITY NOTICE: THIS DRAWING, INCLUDING ANY ATTACHMENTS, IS FOR THE SOLE USE OF THE INTENDED RECIPIENT(S) AND MAY CONTAIN CONFIDENTIAL AND PRIVILEGED INFORMATION. ANY UNAUTHORIZED REVIEW, USE, DISCLOSURE OR DISTRIBUTION IS PROHIBITED. IF YOU ARE NOT THE INTENDED RECIPIENT, PLEASE CONTACT SPECIAL-LITE, INC. AND DESTROY ALL COPIES OF THE ORIGINAL DRAWING.



Special-Lite
ENGINEERED ARCHITECTURAL SOLUTIONS

860 SOUTH WILLIAMS STREET
DECATUR, MICHIGAN 49045
Ph: (800) 821-6531
Fx: (800) 423-7610
www.special-lite.com

UNLESS OTHERWISE SPECIFIED
0.0" ± 0.060"
0.00" ± 0.030"
0.000" ± 0.010"
0.0000" ± 0.002"
∠ ± 2.0°
CORNER RADI 0.015"
ALL MACHINED SURFACES
TO BE FREE OF BURS

DRAWN	Jason Couse	6/29/2018
CHECKED		
APPROVED		
MFG		
MATERIAL		

TITLE		2" Mitered Trim Clip Diagram	
SIZE	FILE NAME	REV	
B	487 Clip Drawing (2 inch trim Mitered).dwg		
SCALE	PART #	SHEET 7 OF 8	
.375			

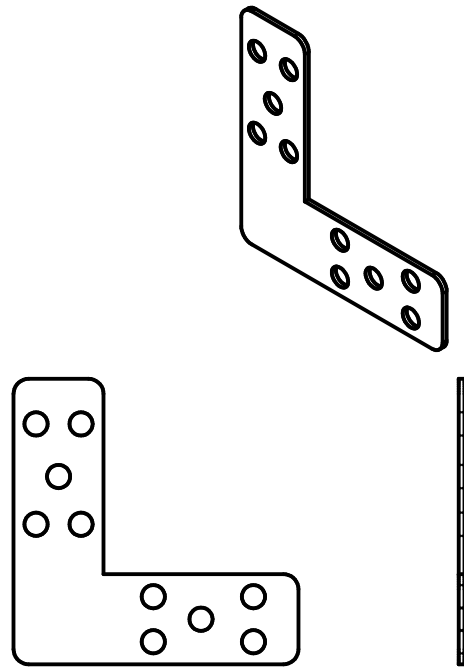

Corner Clip

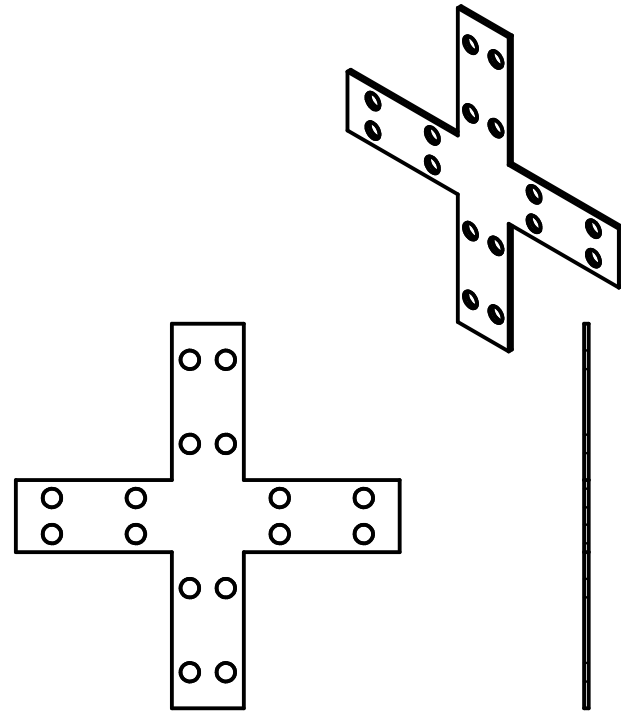

Cross Clip

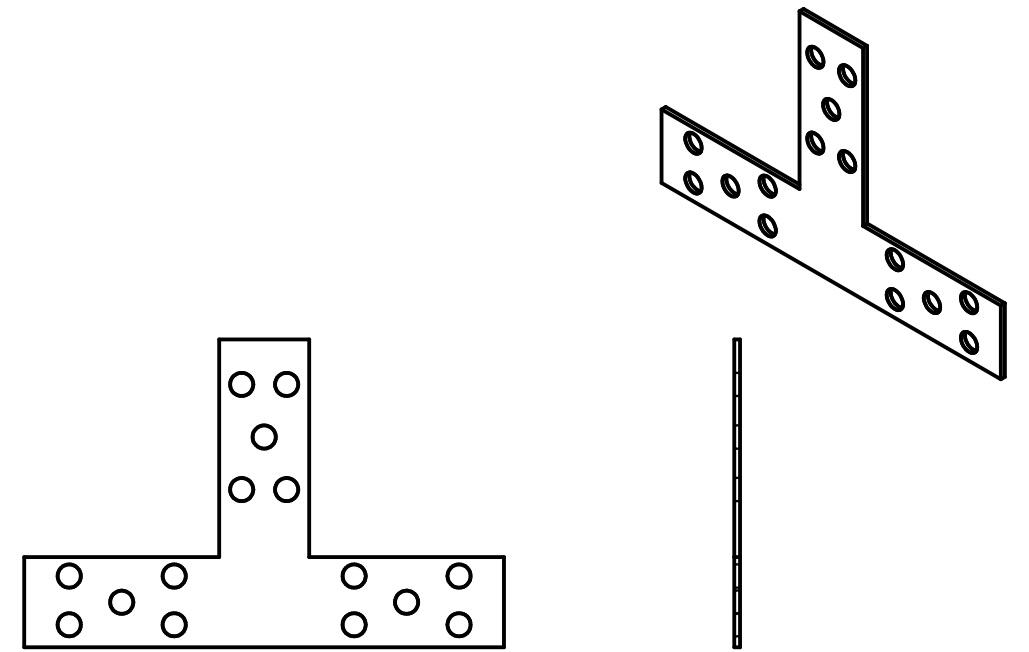

T Clip

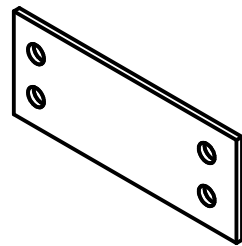

Mullion Clip

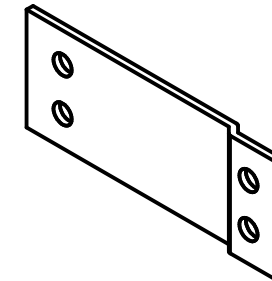
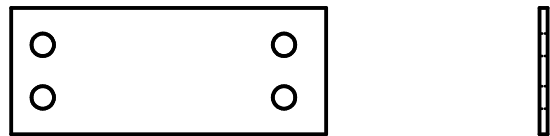

Bent Mullion Clip



CONFIDENTIALITY NOTICE: THIS DRAWING, INCLUDING ANY ATTACHMENTS, IS FOR THE SOLE USE OF THE INTENDED RECIPIENT(S) AND MAY CONTAIN CONFIDENTIAL AND PRIVILEGED INFORMATION. ANY UNAUTHORIZED REVIEW, USE, DISCLOSURE OR DISTRIBUTION IS PROHIBITED. IF YOU ARE NOT THE INTENDED RECIPIENT, PLEASE CONTACT SPECIAL-LITE, INC. AND DESTROY ALL COPIES OF THE ORIGINAL DRAWING.

UNLESS OTHERWISE SPECIFIED
 0.0" ± 0.060"
 0.00" ± 0.030"
 0.000" ± 0.010"
 0.0000" ± 0.002"
 < ± 2.0°
 CORNER RADI 0.015"
 ALL MACHINED SURFACES
 TO BE FREE OF BURRS



Special-Lite[®]

ENGINEERED ARCHITECTURAL SOLUTIONS

860 SOUTH WILLIAMS STREET
 DECATUR, MICHIGAN 49045
 Ph: (800) 821-6531
 Fx: (800) 423-7610
 www.special-lite.com

DRAWN
 Jason Couse

6/29/2018

CHECKED

APPROVED

MFG

MATERIAL
 Steel, Galvanized

TITLE

Clips

SIZE

B

FILE NAME

487 Clip Drawing (2 inch trim Mitered).dwg

SCALE

.625

PART #

SHEET 8 OF 8

REV