

Finish:

Clear Anodized
 Black Anodized
 Other: _____

Series:

375 (3-3/4" Wall)
 487 (4-7/8" Wall)
 725 (7-1/4" Wall)
 Adjustable: _____
 3" - 9-1/2" Available; Enter Size

Trim:

100 (1")
 103-1 (1-1/2")
 103-2 (2")

Door Gasket:

Gray Vinyl
 Black Vinyl
 Gray Mohair
 Black Mohair

Fire Rating:

20-Minute
 90-Minute*
 S-Label

*90-Min only available for 3-3/4" to 10-1/8"

Trim Corner Style:

Square
 Miter

Closer Reinforcement:

Regular Arm
 Parallel Arm

LH/RHR Quantity: _____

Mark #: _____



RH/LHR Quantity: _____

Mark #: _____

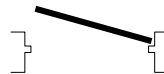

Special Instructions: Provide template for any special prep.

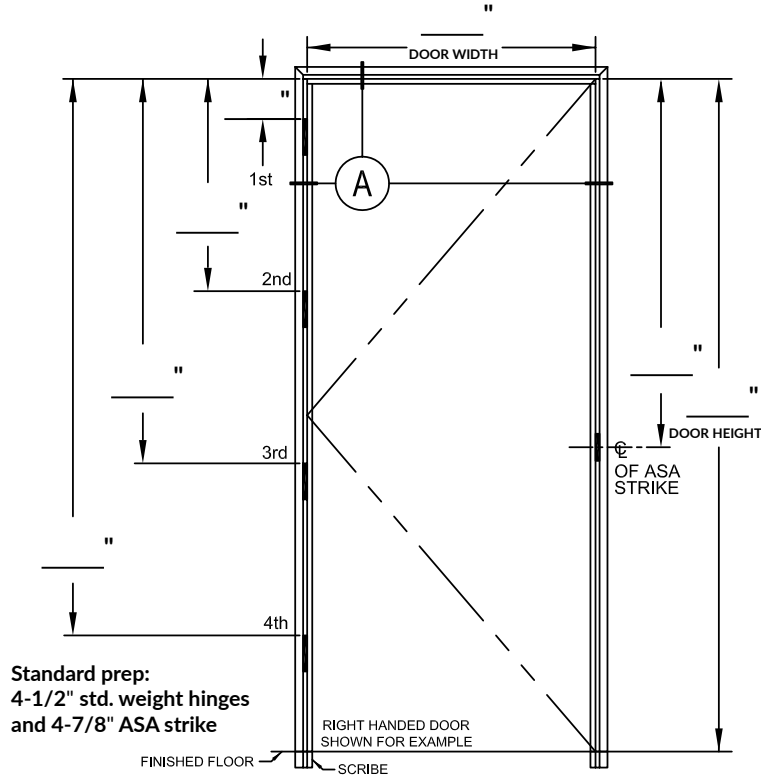

Standard prep:
 4-1/2" std. weight hinges
 and 4-7/8" ASA strike

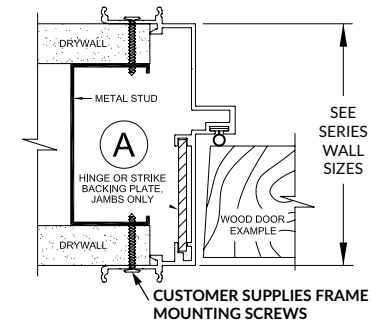

2" Scribe:

Yes
 No

Blank Elevation Form is available for complicated elevations.